

RONDA startech 5000

Chronographs, Big Date & Date,
different calendar systems, Alarm

Caliber 5130.D – 12½'''

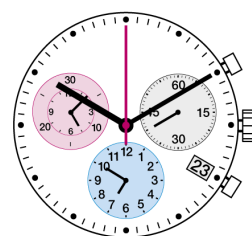
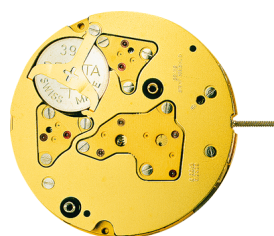

Product Specifications

Analog quartz movement	
Line	startech
Caliber	5130.D
Size	12½'''
Version	Swiss Made Swiss Parts
	13 Jewels / gold plated 6 Jewels / nickel plated
Standard battery life	48 months
Hand fitting height	2

Features

- Repairable metal watch movement
- Very long battery life
- Power saving mechanism with pulled out stem: Reduction of consumption approximately 70%
- Very easy handling by two pushers

Functions

- 3 eyes
- Chronograph
- Chrono-Alarm
- Center stop second (1/1 sec)
- 30 minute / 12 hour counter
- Date
- ADD and SPLIT functions
- Small second
- Alarm

Technical Specifications

Diameter Total	28.60 mm
Case fitting	28.00 mm
Movement height	4.40 mm
Height over standard battery	4.40 mm
Movement rest	0.60 mm
Height over stem	1.90 mm
Length of stem travel	0.90 mm
Force to push the stem for screwed crown	10 / 15 N
Stem thread	0.90 mm
Standard battery	395
Standard battery life	48 months
Battery voltage	1.5 V
Current consumption – typical	1.48 µA (Date Mechanism not in Gear)
Current consumption – maximum	1.65 µA (Date Mechanism not in Gear)
Useful torque second – typical	6 µNm
Useful torque minute – typical	300 µNm
Useful torque center stop second – typical	7 µNm
Operating temperature	0 - 50 °C
Instantaneous rate	-10/ +20 sec/month
Resistance to magnetic fields	18.8 Oe
Resistance against shock	NIHS 91-10



Angle Winkel Angle	30°	
Ø Dp	b	
1.00	13.50	
1.10	13.50	
1.20	13.50	
1.30	13.50	
1.40	13.50	

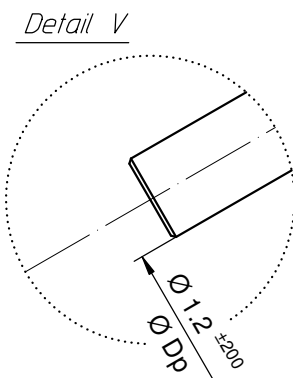
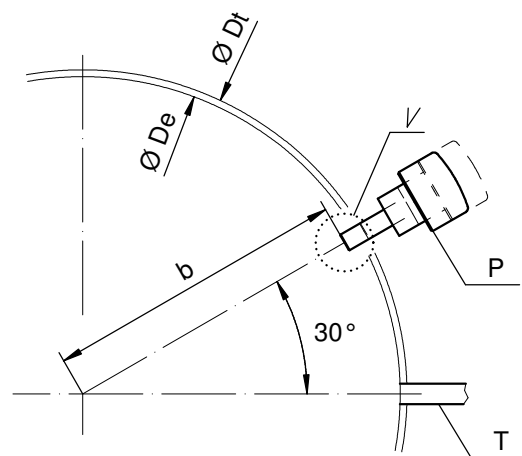

Angle Winkel Angle	0°	
Ø Dp	a	b
1.30	7.40	11.43
1.40	7.45	11.40

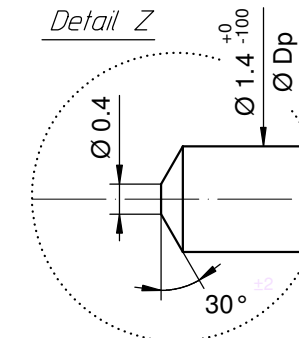
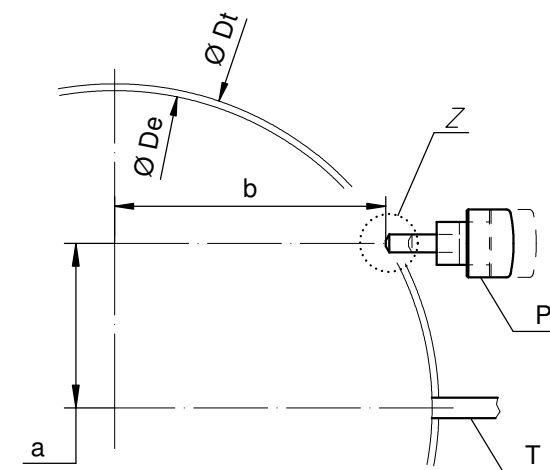

Angle Winkel Angle	20°	
Ø Dp	a	b
1.30	2.57	13.22
1.40	2.59	13.21

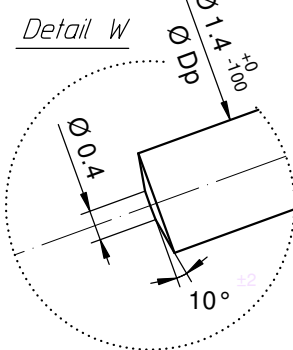
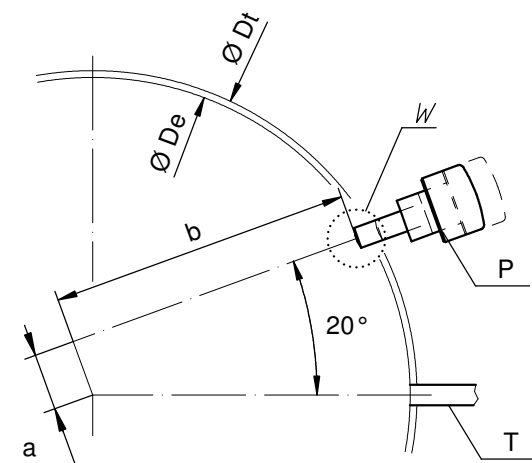

Ø De: diamètre d'encageage
Durchmesser der Gehäusepassung
fitting-diameter

Ø Dp: diamètre du poussoir
Drückerdurchmesser
pusher-diameter

Ø Dt: diamètre total
Totaldurchmesser
total-diameter

P: poussoir en position poussée
Drücker in gedrückter Stellung
pusher in pressed position

T: tige de mise à l'heure
Stellwelle
stem

Angle Winkel Angle	15°	
Ø Dp	a	b
1.30	3.83	12.92
1.40	3.86	12.91

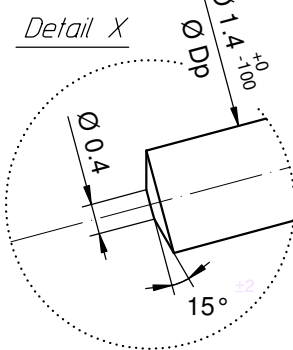
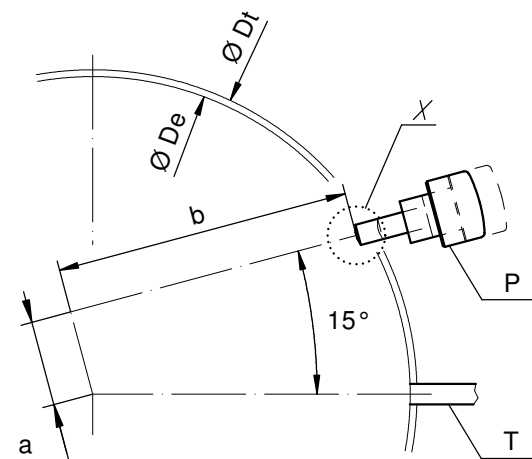

Angle Winkel Angle	10°	
Ø Dp	a	b
1.30	5.06	12.52
1.40	5.10	12.50

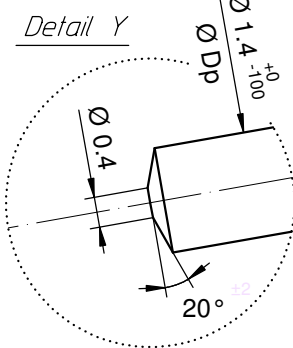
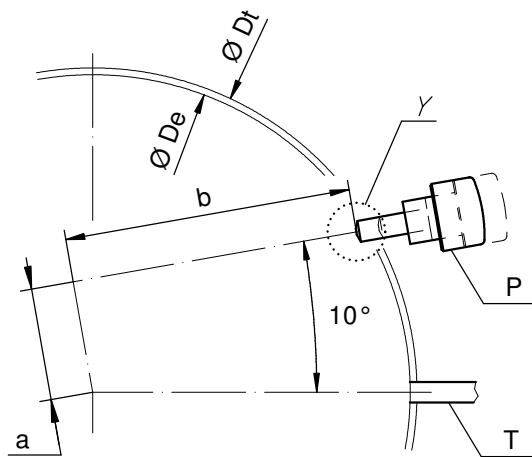

Angle des poussoirs A et B
Winkel der Drücker A und B
Angle of pusher A and B

RONDA 4xxx.x, 5xxx.x

Issued	06 Sep 2004	mk
Modified	30.März 2005 ÄA 1784	mk
Released	YES	
Tolerance	+/- 20 µm	
Scale	10 : 1 (5 : 1) (A3H)	
Sous réserve de modifications Änderungen vorbehalten Modifications reserved		
No.	5000.345	01

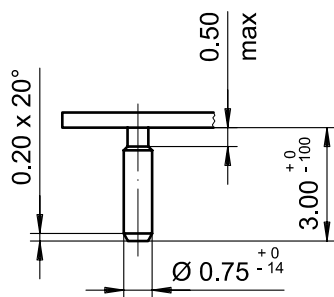
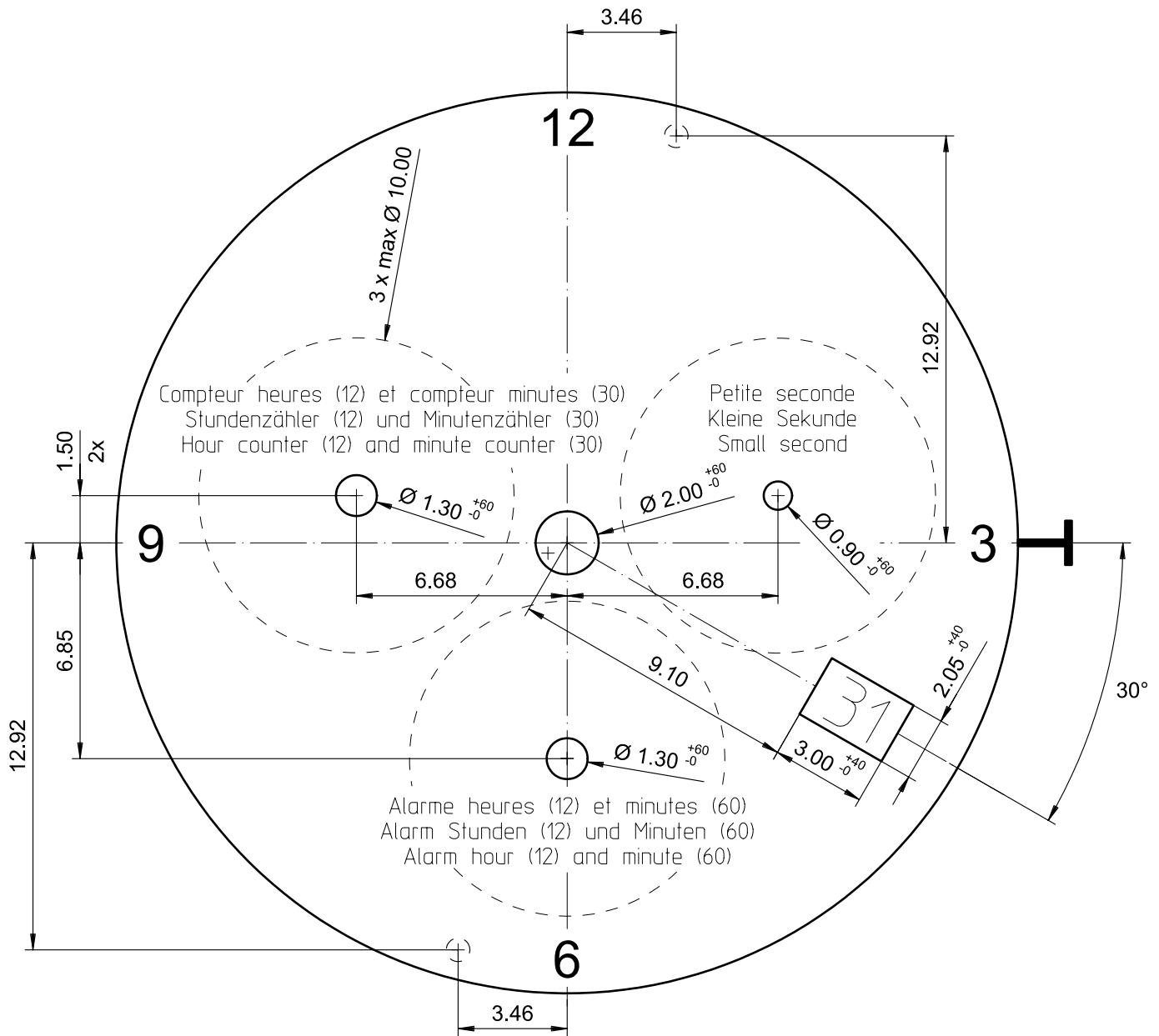

Epaisseur du cadran selon hauteur de l'aiguillage
Zifferblattdicke gemäss Zeigerwerkhöhen
Dial thickness according to hand fitting heights

Tige	Date
Stellw.	Datum
Stem	Date
3H	4H

Cadran
Zifferblatt
Dial

12 1/2"

Issued	13 Dez 2006	cw
Modified	15.Dez.2006 ÄA ----	cm
Released	YES	
Tolerance	+/- 20 µm	
Scale	5 : 1 (A4V)	

RONDA

5130.D

Sous réserve de modifications
Änderungen vorbehalten
Modifications reserved

No. 5010.618 01

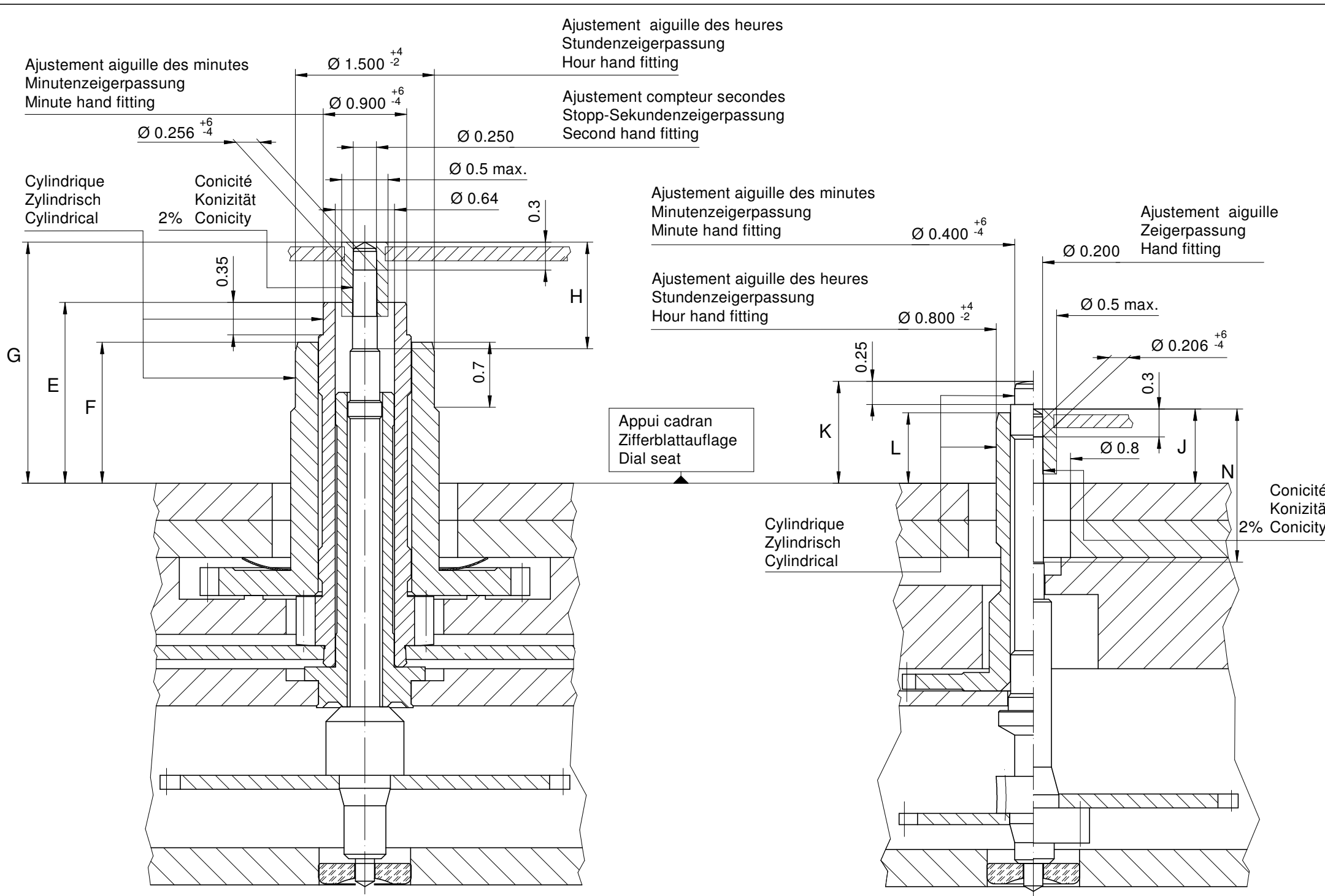

Aiguillages Zeigerwerkhöhe Hand fitting height								
Dépassement Höhe über Zifferblattauflage Height over dial seat								
No	G	E	F	H	N	Compteur 2 aig. 2 Zeiger Zähler 2 Hand counter		J
						K	L	
2	2.60	1.95	1.52	1.15	1.65	1.10	0.76	0.80
-								

Heures / minutes / secondes chrono
Stunden / Minuten / Stopp-Sekunden
Hours / minutes / chrono second

Compteur 2 aiguille
2 Zeiger Zähler
2 Hand counter
Petite seconde
Kleine Sekunde
Small second

Aiguillages Zeigerwerkhöhe Hand fitting height								
Peinture comprise / inkl. Farbe / Paint included								
Epaisseur maximum du cadran Maximale Zifferblattstärke Maximum dial thickness								
No	Sous l'aiguille des secondes chrono Unter Stopp-Sekundenzeiger Under chrono second hand	Sous l'aiguille des minutes Unter Minutenzeiger Under minute hand	Sous l'aiguille des heures Unter Stundenzeiger Under hour hand	Compteur 2 aig. 2 Zeiger Zähler 2 Hand counter		Sous l'aiguille de petite seconde Unter kleine Sekundenzeiger Under small second hand	Epaisseur des aiguilles Zeigerdicke Hands thickness	
				minutes Minutenzeiger minute hand	heures Stundenzeiger hour hand			
2	2.10	1.55	1.10	0.70	0.40	0.40	0.15	
-								

		Aig. des sec. chrono Stopp-Sekundenzeiger Chrono second hand	Aig. des minutes Minutenzeiger Minute hand	Aig. des heures Stundenzeiger Hour hand	Compteur 2 aiguille 2 Zeiger Zähler 2 Hand counter		Aig. petite secondes Kleine Sekundenzeiger Small second hand	Lors de la pose d'aiguilles, le mouvement doit être soutenu. Beim Zeigersetzen muss das Werk abgestützt werden. The movement needs to be supported for hand setting.
		mg max.	µNm max.	gmm ² max.	N max.	minutes Minutenzeiger Minute hand	heures Stundenzeiger Hour hand	
Masse / Masse / Weight *		10	30	30	10	10	10	
Balourd / Unwucht / Unbalance *		0.06	0.80	0.80	0.03	0.03	0.07	
Inertie / Massenträgheit / Inertia *		1.0	-	-	1.0	-	0.4	
Force de chassage / Aufpresskraft / Force		30	40	40	30	30	30	

Aiguillages Zeigerwerkhöhe 12½" Hand fitting heights

RONDA 5020.B, 5130.D, 5130.B

Issued	14 Nov 2003	mk
Modified	15 Okt 2014 ÄA 13275	dh
Released	Yes	
Tolerance	µm	
Scale	20 : 1 (A3H)	
Sous réserve de modifications Änderungen vorbehalten Modifications reserved		
No.	3316.081	07

* En cas de données différentes, veuillez contacter le service après-vente * Bei abweichenden Werten, bitte technischen Kundendienst anfragen * In case of different values, please contact the customer service

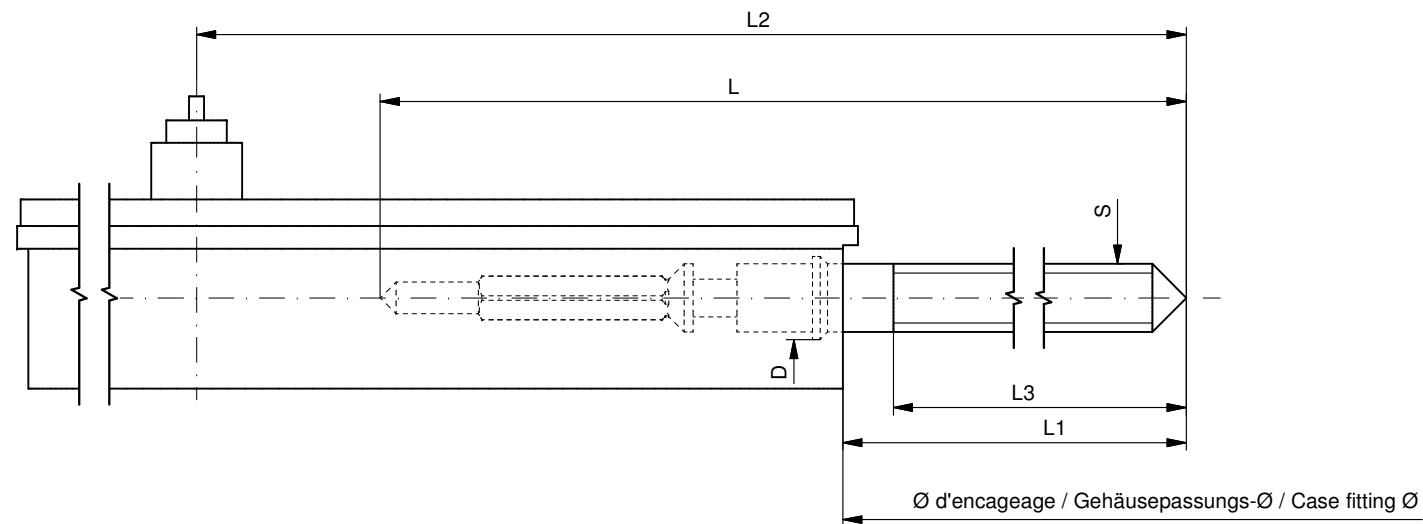

Tige de travail (intégrée dans le mouvement)
 Arbeitstellwelle (im Werk eingebaut)
 Working stem (implemented in the movement)

No. d'article Artikelnummer Part number	L	L1	L2	L3	S	D
3000.177.CO	20.00	10.23	24.23	10.15	0.90	1.10

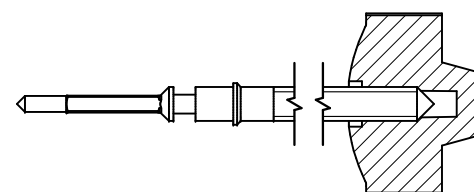

Couleur de la couronne Kronenfarbe Crown color	bleu foncé dunkelblau dark blue
Code	UN 5002

Tige (normale) / Stellwelle (normal) / Stem (normal)

No. d'article Artikelnummer Part number	L	L1	L2	L3	S	D
3000.177	20.00	10.23	24.23	10.15	0.90	1.10
3000.191	32.00	22.23	36.23	22.15	0.90	1.10

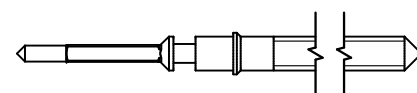

Couronne normale
 Normale Krone
 Normal crown

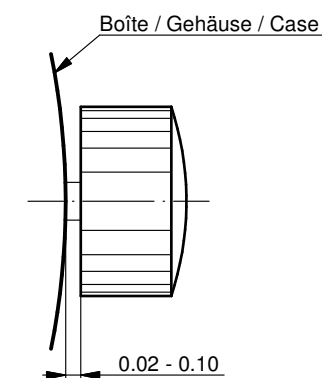

Couronne vissée
 Geschraubte Krone
 Screwed crown

Force ⇐ min. Kraft ⇐ min. Force ⇐ min.	10 N
Force ⇐ max. Kraft ⇐ max. Force ⇐ max.	15 N

Rallonge de tige / Stellwelle Verlängerung / Stem extension

No. d'article Artikelnummer Part number	L4	L5 (min)	L6	S1	S2	D1
3000.040	12.00	1.90	2.60	0.90	0.90	1.35

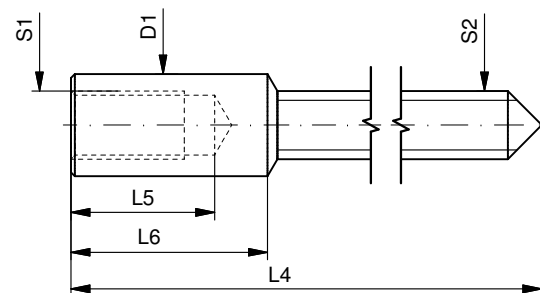

Tige (dimensions / forces)
 Stellwelle (Dimensionen / Kräfte)
 Stem (dimensions / forces)

RONDA

5010.B, 5020.B, 5021.D, 5030.D,
 5040.B, 5040.D, 5040.E, 5040.F,
 5050.B, 5050.C, 5051.C, 5130.B, 5130.D

Issued	05 Sep 2012	ds5222
Modified	17 Mär 2017 ÄA 34582	mg5224
Released	YES	
Tolerance	---	
Scale	10:1 (A3)	

Sous réserve de modifications
 Änderungen vorbehalten
 Modifications reserved

No.	5030.019	01
-----	----------	----



Movement holder
Removing setting stem
H5XXX.1T



Movement holder
Setting hands
H5XXX.1A4



PCB-Alarm
Installing Piezo function for
H5XXX.1A4
H5XXX.1P

Fitting dial and hands

- Crown in position III
- Wind hour hand forwards, until date changes
- Remove working hand
- Mount dial
- Point all hands towards 12 o'clock
- Fit time
- Zero chronograph hand*
- Crown in position II
- Install alarm reference time**
- Set date
- Crown in position I

Date switching duration

First and tenth digit discs

~2hrs

*Zeroing the Chronograph hand

- Press pushers A and B for 2 seconds at the same time
(Chrono seconds hand rotates once)
- Pusher A → to correct chrono seconds hand
- Pusher B → to jump to hour and minute hands
- Pusher A → to correct hand position

Details: See Instruction Manual

**Setting alarm reference time

- Press pusher B min. 2 secs (Reference time mode is activated)
- Using pusher B, synchronise reference time with actual time:
 - Short press (< 1 sec.) → +1 minute
 - Medium press (1-2 secs) → +1 hour
 - Long press (> 2 secs) → continuous

Details: See Instruction Manual

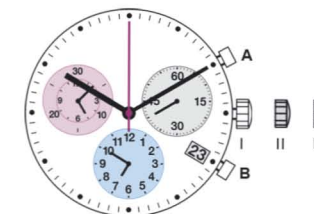

General Instructions

Removing the setting stem can only be effected in Pos. I.

The use of supporting screws is essential when mounting the hands.

Permitted hand setting strengths:

Hr / min. hands: <40N

Other hands: <30N

During quick date correction (setting stem in position II), a date switching speed of 5 d/s must not be exceeded.

Alarm reference time tip

The reference time runs in the background, behind the watch time, on which the ALARM time is based. So with every new time setting, the reference time must be freshly synchronised.

You have decided to buy a watch, which was assembled by a watchmaker using a Ronda movement. Please note that no watches are produced or distributed under the Ronda Brand.

In case of repairs, guarantee claims and questions concerning the functioning of a watch, purchasers and consumers should contact their retailer or the watch manufacturer, for which the relevant information can be found in the sales or guarantee documentation provided with the watch.

Description of the display and control buttons

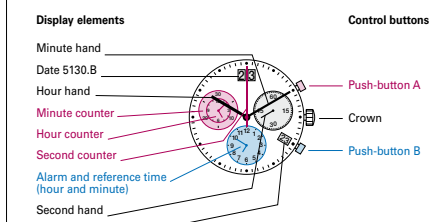

01

Multifunction movement

The alarm and chronograph are combined in Cal. 5130.D and 5130.B. All functions can be operated with the 2 push-buttons and crown.

Initial status (chronograph hands at zero position)
 - start the chronograph with push-button A
 - switch the alarm on and off with push-button B

Chronograph active
 Push-button B is also operative for the chronograph as soon as timing is started with push-button A.
 At the end of timing and when the chronograph hands are reset to the zero positions the push-button functions once again assume their 'initial status'.

The alarm cannot be adjusted when the chronograph is active.

02

Setting the time

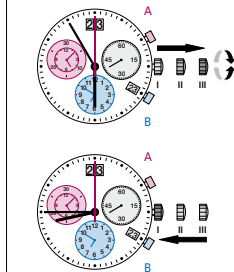

03

- 1* Pull out the crown to position III (the watch stops).
- 2 Turn the crown until you reach the correct time 8:45.
- 3* Push the crown back into position I.

Please note:
 * In order to set the time to the exact second, 1 must be pulled out when the second hand is in position «60». Once the hour and minute hands have been set, 2 must be pushed back into position I at the exact second.

Setting the date (quick mode)

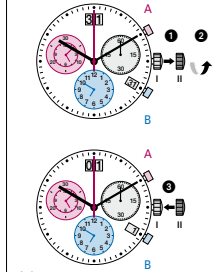

04

- 1 Pull out the crown to position II (the watch continues to run).
- 2 Turn the crown until the correct date [01] appears.
- 3 Push the crown back into position I.

Please note:
 The date of the following day must be set in the calendar changing phase between approx. 9 PM and midnight.
 5130.B: Setting the date too quickly in quick mode can result in the incorrect date being displayed. Switching the date between 01 and 31 (position II) restores the synchronisation.

Setting the time and date

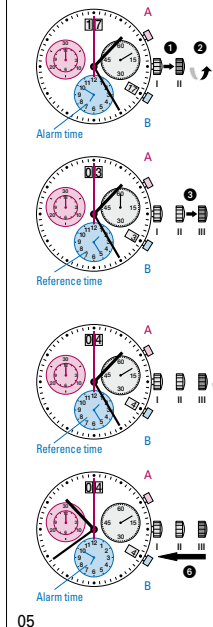

05

- Example:**
 - Date / time on the watch: [17] / 1:25 AM
 - Present date / time: [04] / 10:39 PM
- 1 Pull out the crown to position II (watch continues to run).
 - 2 Turn the crown until yesterday's date appears [03].
 - 3 Pull out the crown to position III (the display changes from alarm time to reference time.)
 - 4 Turn the crown until the correct date [04] appears.
 - 5 Continue to turn the crown until the current time 10:39 PM appears.
 - 6 Push the crown back into position I (the display changes from reference to alarm time).

Please note:
 Resetting the time also requires the identical correction of the reference time.
 Please refer to «setting the reference time».
 * Please observe the AM/PM clock rhythm.

Setting the alarm time

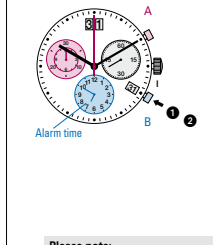

06

- 1 **Activate the setting mode**
 Press the push-button B for at least 2 seconds. As soon as the small minute hand jumps forward 1 minute, this mode is active.
- 2 **Setting**
 Short pressing (less than 1 second): the alarm time is moved forward by the minutes.
 Long pressing (longer than 2 seconds): the alarm time is moved forward until the push-button is released.

Please note:
 If the push-button B is not activated for 10 seconds, the setting mode of the alarm time deactivates itself. At the same time, 2 beeps are emitted to indicate that the alarm is switched on.

Please note:
 The alarm cannot be used as long as the chronograph is in operation.

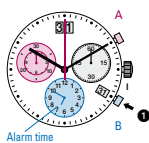

07

Switching the alarm on/off

- 1 The alarm is switched on/off by briefly pressing the push-button B:
- 2 beeps → alarm switched on
- 1 beep → alarm switched off

Please note:
 The alarm can be set maximum 12 hours before the desired alarm time.
 Once the set alarm time has been reached, a signal is emitted for 20 seconds. This signal is repeated after two minutes. Following brief pressing of the push-button B, the signal is immediately switched off.

Setting the reference time

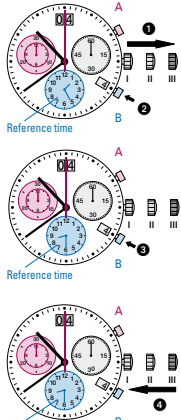

08

- 1 Pull out the crown to position III (second hand stops. The display changes from alarm time to reference time.)
- 2 **Activating the setting mode**
 Press the push-button B for at least 2 seconds. As soon as the small minute hand jumps forwards one minute, this mode is active.
- 3 **Short pressing** (less than 1 second): the reference time is moved forwards by the minute.
Medium pressing: (1–2 seconds): the reference time is moved forwards by the hour.
Long pressing (longer than 2 seconds): the reference time is moved forwards until the push-button is released.
- 4 Push the crown back into position I (the display changes from reference time to alarm time). A 1 beep signal indicates that the alarm is switched off.

Please note:
 The reference time must display the same time as the current time. This means that resetting the current time also requires the identical correction of the reference time. Afterwards, the alarm time has to be reset.

What is the reference time?

The current time is displayed by means of the hour and minute hand.
 Parallel to the current time, the reference time runs in the background; the alarm time refers itself to this reference time. Thus, resetting the time also requires the identical correction of the reference time.
 If the reference time is not synchronised with the current time, this results in the alarm signal being emitted at a different time to the set alarm time.

Chronograph: Basic function

(Start / Stop / Reset)

- Example:**
 1 **Start:** Press push-button A.
 2 **Stop:** to stop the timing, press pushbutton A once more and read the chronograph counters:
 4h / 20 min / 38 sec
 3 **Zero positioning:**
 Press push-button B. (The chronograph hands will be reset to their zero positions.)

Please note:
 The alarm cannot be used as long as the chronograph is in operation.

09

Chronograph: Accumulated timing

- Example:**
 1 **Start:** (start timing)
 2 **Stop:** (e.g. 15 min 5 sec following 1)
 3 **Restart:** (timing is resumed)
 4 **Stop:** (e.g. 5 min 12 sec following 3) = 20 min 17 sec (The accumulated measured time is shown)
 5 **Reset:**
 The chronograph hands are returned to their zero positions.
- Please note:**
 * Following 4, the accumulation of the timing can be continued by pressing push-button A (Restart / Stop, Restart / Stop, ...).

10

Chronograph: Intermediate or interval timing

- Example:**
 1 **Start:** (start timing)
 2 **Display interval:**
 e.g. 20 minutes 17 seconds (timing continues in the background)
 3 **Making up the measured time:**
 (the chronograph hands are quickly advanced to the ongoing measured time).
 4 **Stop:** (Final time is displayed)
 5 **Reset:**
 The chronograph hands are returned to their zero position
- Please note:**
 * Following 3, further intervals or intermediates can be displayed by pressing push-button B (display interval / make up measured time, ...).

11

Adjusting the chronograph hands to zero position

- Example:**
 One or several chronograph hands are not in their correct zero positions and have to be adjusted (e.g. following a battery change).
 1 Pull out the crown to position III (all chronograph hands are in their correct or incorrect zero position. The display changes from alarm time to reference time.)
 2 Keep push-buttons A and B depressed simultaneously for at least 2 seconds (the second counter hand rotates by 360° → corrective mode is activated.)

12

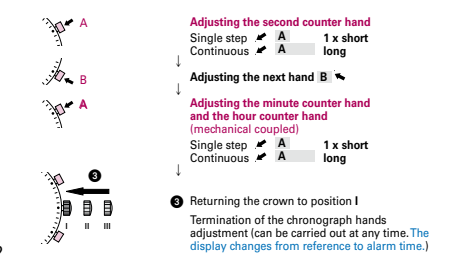

Adjusting the second counter hand
 Single step: A 1 x short
 Continuous: A long

Adjusting the next hand B

Adjusting the minute counter hand and the hour counter hand
 Single step: A 1 x short
 Continuous: A long

- 3 Returning the crown to position I
 Termination of the chronograph hands adjustment (can be carried out at any time. The display changes from reference to alarm time.)



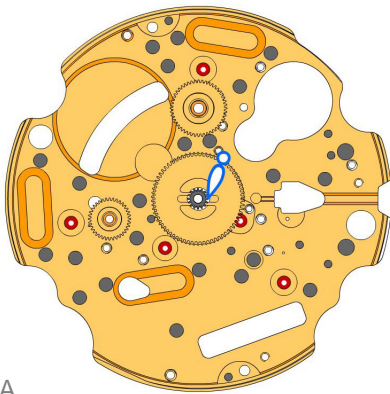



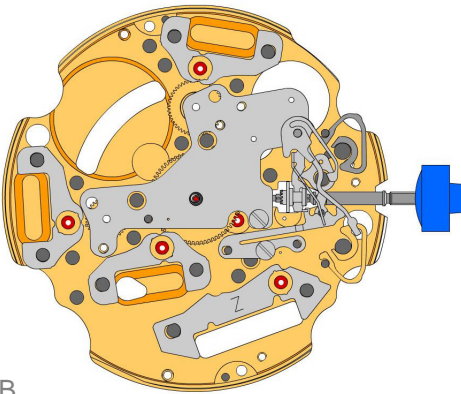









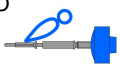









A



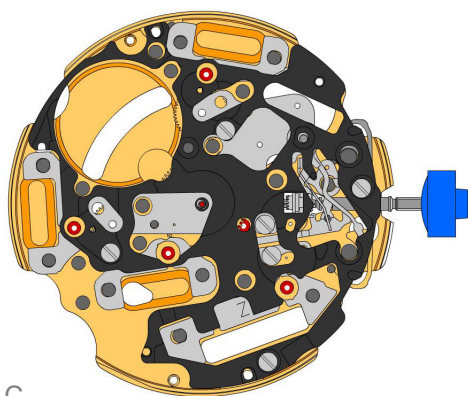



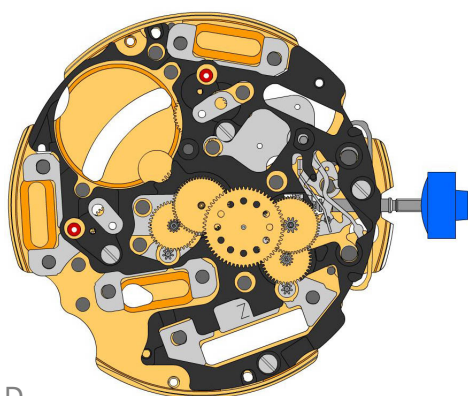

B

2000.574.G 1.		Main plate
3305.282.CO 2.		Cannon pinion with driver (Aig.2)
3301.243 3.		Hour wheel (counter 12h) (Alarm)
3301.244 4.		Hour wheel (counter 24h) (Chrono)
2030.017.CO 5.		Centre bridge Centre bridge held by 1 screw 4000.250.
4000.250 6.		Screw
3001.055.FI 7.		Sliding pinion
3000.177.CO 8.		Setting stem
3017.049 9.		Setting lever
3905.049 10.		Setting lever jumper (3 positions) Setting lever jumper held by 1 screw 4000.250.
4000.250 11.		Screw
3015.081 12.		Yoke (3 positions)
3905.067 13.		Yoke spring Tensioning the spring arm.
3406.030 14.		Pusher jumper B Put the grey jumper between the two posts on the further side.
3406.038 15.		Pusher jumper A Put the yellow jumper between the two posts on the closer side.
3622.040 16.		Stator Mark [Z] on stator.
3622.039 17.		Stator (counter 6h, 9h, chrono)
3622.039 18.		Stator (counter 6h, 9h, chrono)
3622.039 19.		Stator (counter 6h, 9h, chrono)





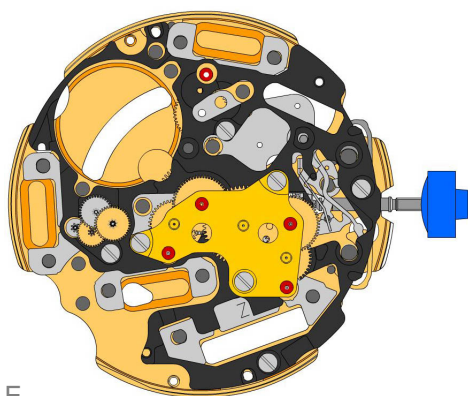

C

3603.079 20.		Plastic bracket Plastic bracket held by 4 screws 4000.250.
4000.250 21.		Screw
3715.094.RK 22.		Rotor
3715.094.RK 23.		Rotor



D

3147.046.CO 24.		Intermediate wheel
3136.142.CO 25.		Second wheel (long)
3147.047.CO 26.		Intermediate wheel (chrono)
3136.144.CO 27.		Chronograph wheel (Aig.2)
3122.056.CO 28.		Third wheel

E

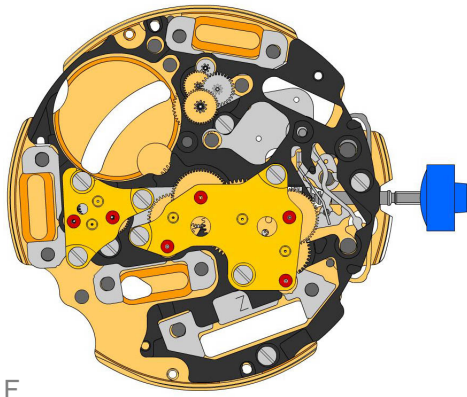
2020.148.G 29.		Train wheel bridge Train wheel bridge held by 3 screws 4000.250.
4000.250 30.		Screw
3715.095.RK 31.		Rotor
3147.048.CO 32.		Intermediate wheel (counter)
3007.056.CO 33.		Minute wheel (counter 24h)
3402.008.CO 34.		Minute counting wheel

F

2020.149.G
35.  Counter train wheel bridge
Counter train wheel bridge held by 3 screws 4000.250.

4000.250
36.  Screw

3715.095.RK
37.  Rotor

3147.048.CO
38.  Intermediate wheel (counter)

3007.055.CO
39.  Minute wheel (counter 12h)

3402.007.CO
40.  Minute counting wheel

4000.250
41.  Screw

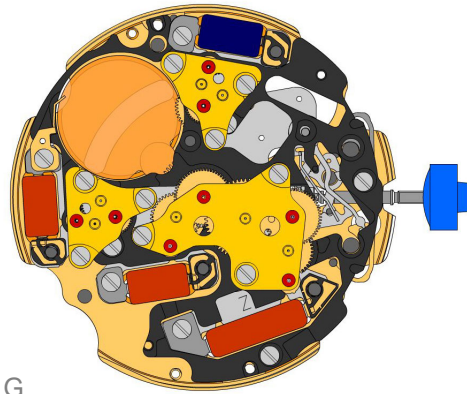

G

2020.149.G
42.  Counter train wheel bridge
Counter train wheel bridge held by 3 screws 4000.250.

4000.250
43.  Screw

3621.053.RK
44.  Coil
Attention: Please hold the coil only on the grey coil core. Coil held by 1 screw 4000.250.









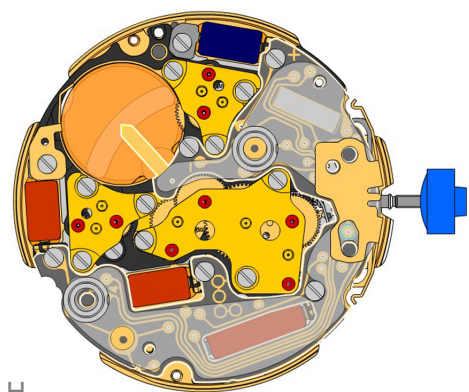
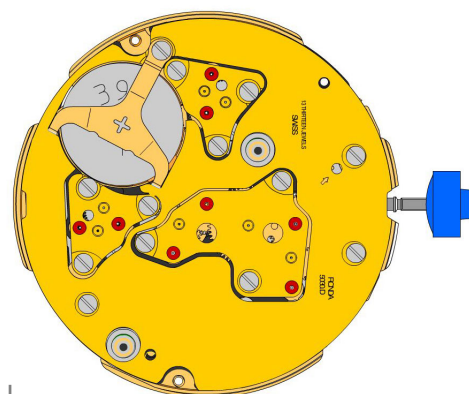



3621.054.RK
45.  Coil (counter 9h, chrono)
Attention: Please hold the coil only on the grey coil core. Coil held by 1 screw 4000.250.

3621.054.RK
46.  Coil (counter 9h, chrono)
Attention: Please hold the coil only on the grey coil core. Coil held by 1 screw 4000.250.

3621.055.RK
47.  Coil (counter 6h)
Attention: Please hold the coil only on the grey coil core. Coil held by 1 screw 4000.250.





4000.250
48.  Screw

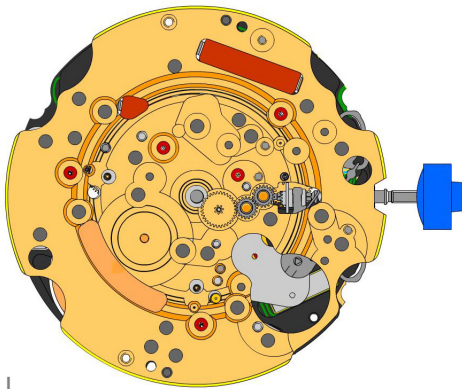

H

I

3601.118 49.		Contact strip Contact strip held by 1 screw 4000.250.
3603.034 50.		Battery insulator
3612.176.5130 51.		Electronic module Electronic module held by 5 screws 4000.250. Electronic measurements may be realised now.
4000.248 52.		Screw
3603.069 53.		Circuit insulator
3603.070 54.		Contact insulator
3603.070 55.		Contact insulator
3601.107.G 56.		Pusher contact spring
2130.159.G.M01.5130D 57.		Electronic module cover Electronic module cover held by 3 screws 4000.250.
3600.010.HGF 58.		Battery 395
3601.109.G 59.		Bridle + Bridle held by 1 screw 4000.250.
4000.250 60.		Screw



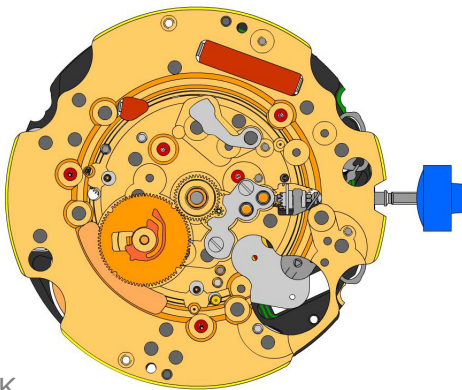





J

2000.574.G 61.		Main plate
3004.164 62.		Setting wheel
3004.164 63.		Setting wheel
3007.054.CO 64.		Minute wheel



K



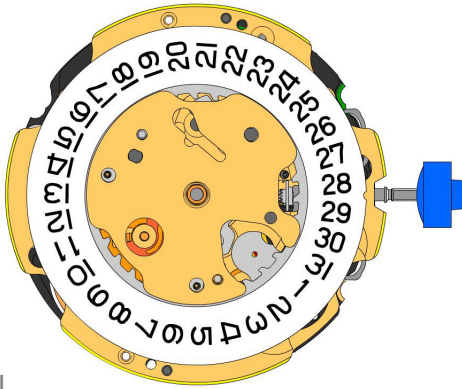



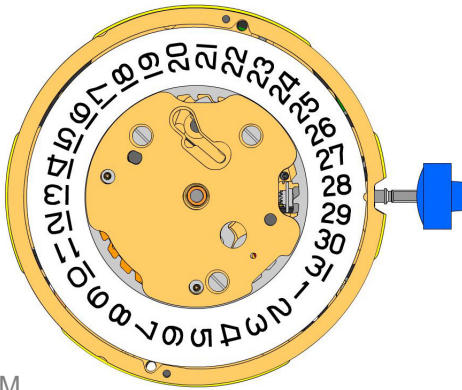



2130.143 65.		Minute train bridge Minute train bridge held by 2 screws 4000.250.
4000.305 66.		Screw
3301.242 67.		Hour wheel (Aig.2)
3315.016 68.		Friction spring
3004.224.CO 69.		Date indicator driving wheel
3500.049 70.		Date jumper



L



M

3504.208.AB.1.A 71.		Date indicator (standard) Nick of the indicator at 3 o'clock.
2130.141 72.		Date indicator maintaining plate Date indicator maintaining plate held by 1 screw 4000.250.
3905.070 73.		Date jumper spring Insert the date jumper spring in the provided opening.
2130.140.G 74.		Date mechanism maintaining plate Date mechanism maintaining plate held by 2 screws 4000.250.
4000.250 75.		Screw
3506.072.G 76.		Dial support
8200 77.		Moebius 8200
9014 78.		Moebius 9014
124 79.		Jismaa 124
9020 80.		Moebius 9020

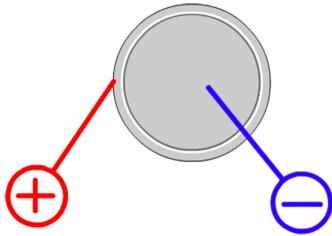

Battery	395
Voltage	1.55 V

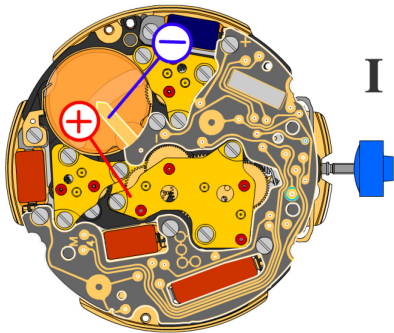

*Setting stem in position I, calendar not in gear,
60 s measuring interval for rate and consumption:*

Typical consumption	1.48 μA
Maximal consumption	1.65 μA
Rate	-10s/M. .. +20s/M.
Lower working voltage limit	1.20 V

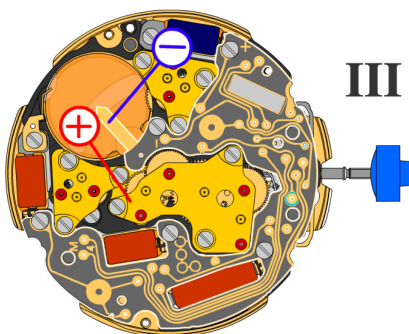

Setting stem in position III, 60 s measuring interval:

Typical consumption	0.10 μA
Maximal consumption	0.30 μA

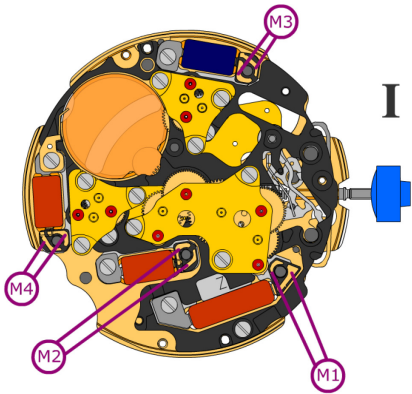

Coil resistance M1 **1.90 k Ω .. 2.20 k Ω**

Coil resistance M2 **1.68 k Ω .. 1.88 k Ω**

Coil resistance M3 **1.68 k Ω .. 1.88 k Ω**

Coil resistance M4 **1.68 k Ω .. 1.88 k Ω**

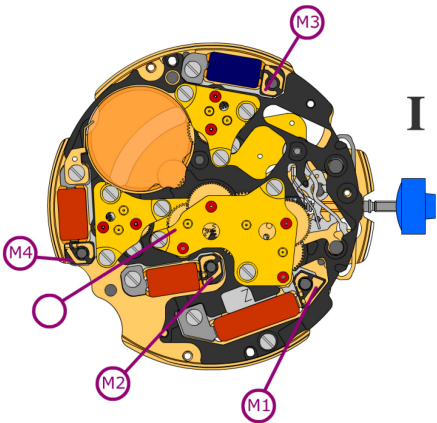



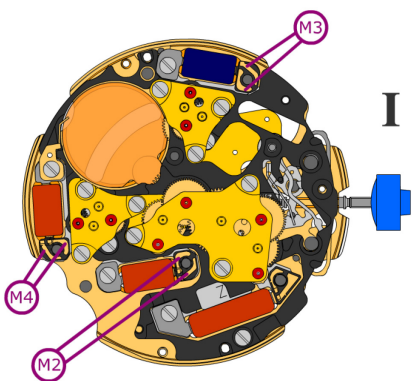





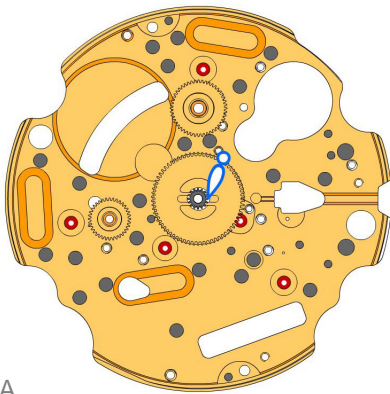
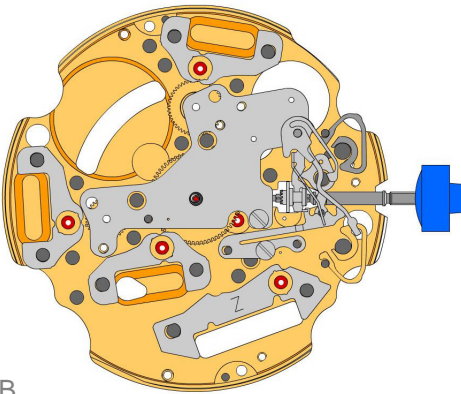











Coil isolation M1/M2/M3/M4 **∞ k Ω**







Signal generator (4.9 ms, 8 Hz):

Lower working voltage limit
M2/M3/M4 **1.20 V**

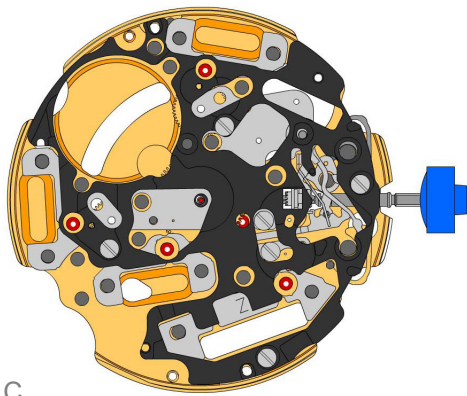



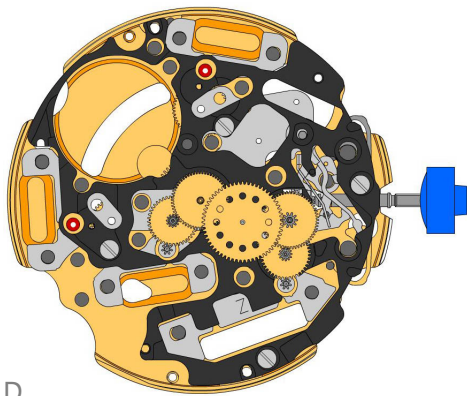

A

B

2000.574.G 1.		Main plate
3305.282.CO 2.		Cannon pinion with driver (Aig.2)
3301.243 3.		Hour wheel (counter 12h) (Alarm)
3301.244 4.		Hour wheel (counter 24h) (Chrono)
2030.017.CO 5.		Centre bridge Centre bridge held by 1 screw 4000.250.
4000.250 6.		Screw
3001.055.FI 7.		Sliding pinion
3000.177.CO 8.		Setting stem
3017.049 9.		Setting lever
3905.049 10.		Setting lever jumper (3 positions) Setting lever jumper held by 1 screw 4000.250.
4000.250 11.		Screw
3015.081 12.		Yoke (3 positions) Parts 3015.081 and 3905.067 must be exchanged together.
3905.067 13.		Yoke spring Tensioning the spring arm. Parts 3015.081 and 3905.067 must be exchanged together.
3406.030 14.		Pusher jumper B Put the grey jumper between the two posts on the further side.
3406.038 15.		Pusher jumper A Put the yellow jumper between the two posts on the closer side.
3622.040 16.		Stator Mark [Z] on stator.
3622.039 17.		Stator (counter 6h, 9h, chrono)
3622.039 18.		Stator (counter 6h, 9h, chrono)
3622.039 19.		Stator (counter 6h, 9h, chrono)





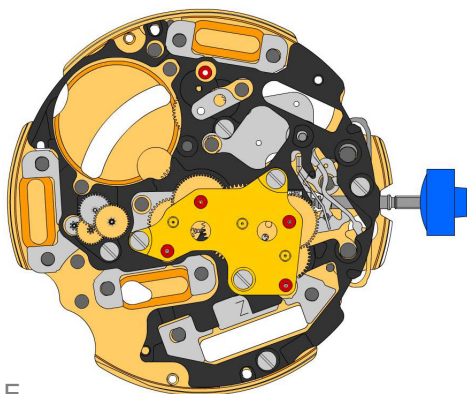

C

3603.079 20.		Plastic bracket Plastic bracket held by 4 screws 4000.250.
4000.250 21.		Screw
3715.094.RK 22.		Rotor
3715.094.RK 23.		Rotor



D

3147.046.CO 24.		Intermediate wheel
3136.142.CO 25.		Second wheel (long)
3147.047.CO 26.		Intermediate wheel (chrono)
3136.144.CO 27.		Chronograph wheel (Aig.2)
3122.056.CO 28.		Third wheel

E

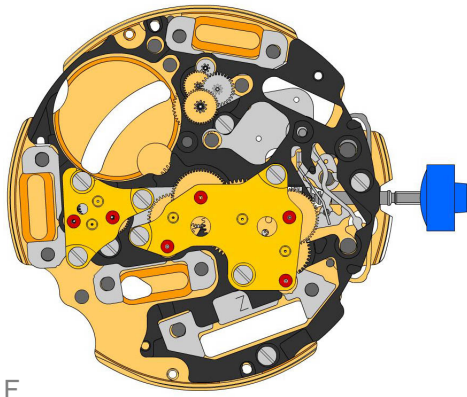
2020.148.G 29.		Train wheel bridge Train wheel bridge held by 3 screws 4000.250.
4000.250 30.		Screw
3715.095.RK 31.		Rotor
3147.048.CO 32.		Intermediate wheel (counter)
3007.056.CO 33.		Minute wheel (counter 24h)
3402.008.CO 34.		Minute counting wheel

F

2020.149.G
35.  Counter train wheel bridge
Counter train wheel bridge held by 3 screws 4000.250.

4000.250
36.  Screw

3715.095.RK
37.  Rotor

3147.048.CO
38.  Intermediate wheel (counter)

3007.055.CO
39.  Minute wheel (counter 12h)

3402.007.CO
40.  Minute counting wheel

4000.250
41.  Screw

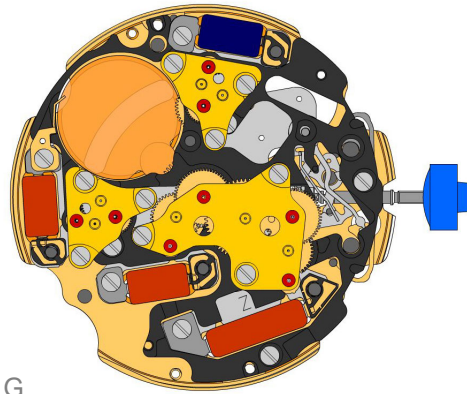

G

2020.149.G
42.  Counter train wheel bridge
Counter train wheel bridge held by 3 screws 4000.250.

4000.250
43.  Screw

3621.053.RK
44.  Coil
Attention: Please hold the coil only on the grey coil core. Coil held by 1 screw 4000.250.









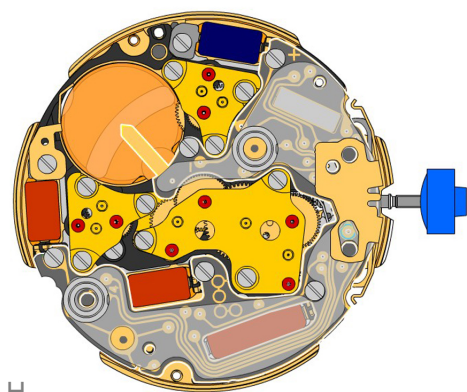
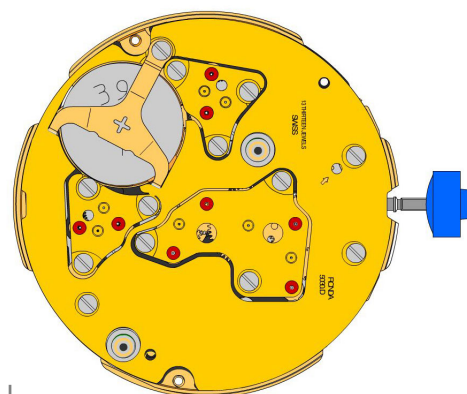



3621.054.RK
45.  Coil (counter 9h, chrono)
Attention: Please hold the coil only on the grey coil core. Coil held by 1 screw 4000.250.

3621.054.RK
46.  Coil (counter 9h, chrono)
Attention: Please hold the coil only on the grey coil core. Coil held by 1 screw 4000.250.

3621.055.RK
47.  Coil (counter 6h)
Attention: Please hold the coil only on the grey coil core. Coil held by 1 screw 4000.250.





4000.250
48.  Screw

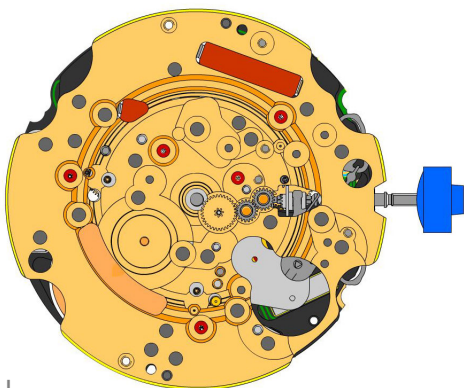

H

I

3601.118 49.		Contact strip Contact strip held by 1 screw 4000.250.
3603.034 50.		Battery insulator
3612.176.5130 51.		Electronic module Electronic module held by 5 screws 4000.250. Electronic measurements may be realised now.
4000.248 52.		Screw
3603.069 53.		Circuit insulator
3603.070 54.		Contact insulator
3603.070 55.		Contact insulator
3601.107.G 56.		Pusher contact spring
2130.159.G.M01.5130D 57.		Electronic module cover Electronic module cover held by 3 screws 4000.250.
3600.010.HGF 58.		Battery 395
3601.109.G 59.		Bridle + Bridle + held by 1 screw 4000.250.
4000.250 60.		Screw



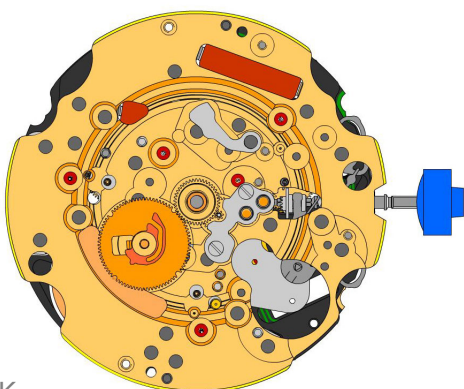





J

2000.574.G 61.		Main plate
3004.164 62.		Setting wheel
3004.164 63.		Setting wheel
3007.054.CO 64.		Minute wheel



K



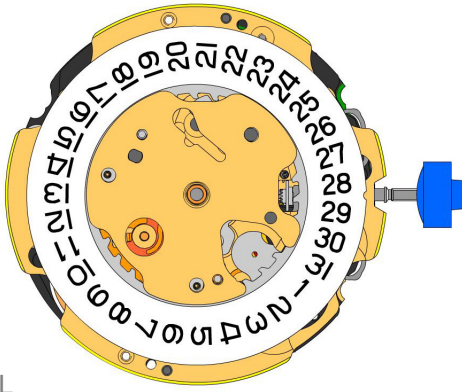



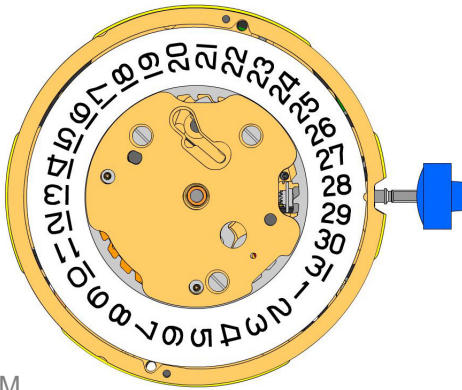



2130.143 65.		Minute train bridge Minute train bridge held by 2 screws 4000.250.
4000.305 66.		Screw
3301.242 67.		Hour wheel (Aig.2)
3315.016 68.		Friction spring
3004.224.CO 69.		Date indicator driving wheel
3500.049 70.		Date jumper



L



M

3504.208.AB.1.A 71.		Date indicator (standard) Nick of the indicator at 3 o'clock.
2130.141 72.		Date indicator maintaining plate Date indicator maintaining plate held by 1 screw 4000.250.
3905.070 73.		Date jumper spring Insert the date jumper spring in the provided opening.
2130.140.G 74.		Date mechanism maintaining plate Date mechanism maintaining plate held by 2 screws 4000.250.
4000.250 75.		Screw
3506.072.G 76.		Dial support
8200 77.		Moebius 8200
9014 78.		Moebius 9014
124 79.		Jismaa 124
9020 80.		Moebius 9020

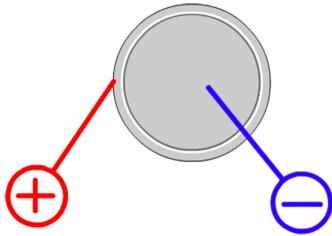

Battery	395
Voltage	1.55 V

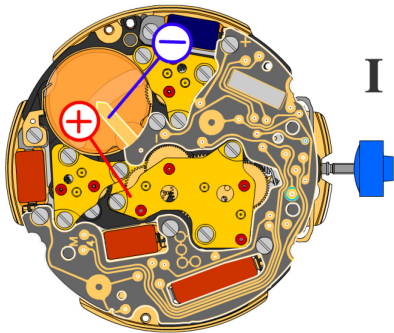

*Setting stem in position I, calendar not in gear,
60 s measuring interval for rate and consumption:*

Typical consumption	1.48 μA
Maximal consumption	1.65 μA
Rate	-10s/M. .. +20s/M.
Lower working voltage limit	1.20 V

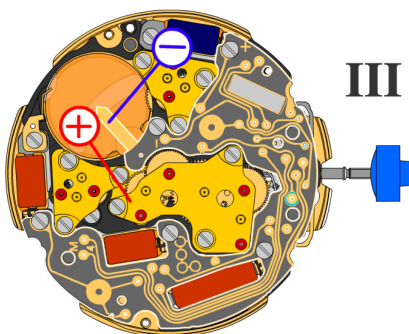

Setting stem in position III, 60 s measuring interval:

Typical consumption	0.10 μA
Maximal consumption	0.30 μA

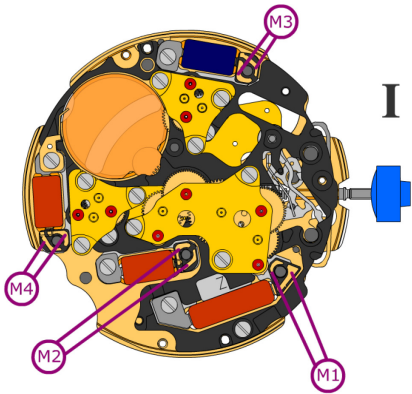

Coil resistance M1 **1.90 k Ω .. 2.20 k Ω**

Coil resistance M2 **1.68 k Ω .. 1.88 k Ω**

Coil resistance M3 **1.68 k Ω .. 1.88 k Ω**

Coil resistance M4 **1.68 k Ω .. 1.88 k Ω**

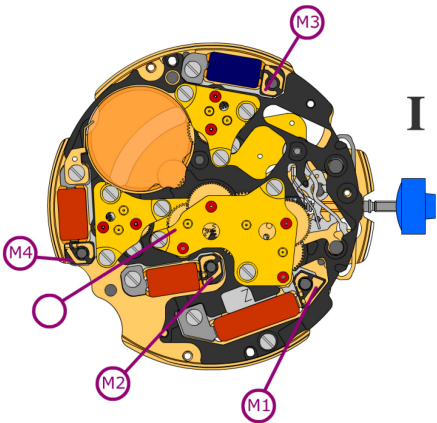

Coil isolation M1/M2/M3/M4 **∞ k Ω**

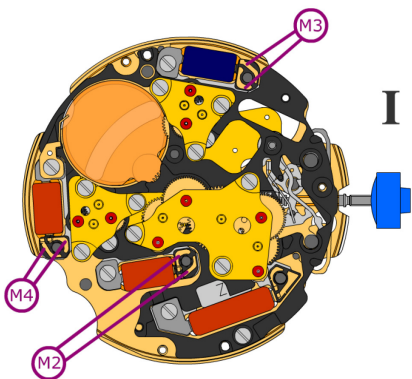

Signal generator (4.9 ms, 8 Hz):

Lower working voltage limit
M2/M3/M4 **1.20 V**